



Product Manual
Installation Instructions

Rear View Camera System

Table of Contents

Important Notice	4
Warning	5
Safety Precautions	5
Before You Begin Installation	6
Installation Diagram	7
Features/Specifications	8
Specifications	9
Positioning	10
Dimensions - Camera	11
Dimensions - Monitor	12
Product Info - Camera	13
Product Info - Monitor	14
Monitor Control and Operation	15
Troubleshooting	16
Warranty	17

IMPORTANT NOTICE

Please read this with manual before proceeding installation.

Congratulations on your purchase of a Rear View Backup Camera System. Your Backup Camera System is designed to provide you with many years of trouble-free.

Installation Location

In some jurisdictions, it is unlawful for a person to drive a motor vehicle equipped with a TV viewer or screen located forward of the back of the driver's seat or in any location that is visible, directly or indirectly, to the driver while operating the vehicle.

In most jurisdictions, it is unlawful for a person to drive a motor vehicle equipped with a TV, TV monitor or screen located forward of the back of the driver's seat or in any

With this manual you will be able to properly install and operate the unit.

The Backup Camera System is intended to be installed as a supplement aid to your standard rear-view mirror that exist in your vehicle. The Backup Camera System is not intended for use as a substitute for rear-view mirror or for any other motor vehicle

WARNING

- The monitor should be situated away from direct sun light, heat, water or moisture. (This product is made with precise electronic components that should be handled with care. Do not let it fail because of improper use.
- Make sure the monitor stand is firmly fixed to secure location.
- Make a hole on vehicle body if necessary, of 3/4" for the camera extension cable connector to pass through during installation.
- Please take special care to the wire positioning while installing the rear view system in order to avoid wiring damage.

Information

IN NO EVENT SHALL SELLER OR MANUFACTURER BE LIABLE FOR ANY DIRECT OR CONSEQUENTIAL DAMAGES OF ANY NATURE, OR LOSSES OR EXPENSES RESULTING FROM ANY DEFECTIVE PRODUCT OR THE USE OF ANY PRODUCT.

SAFETY PRECAUTIONS

- The rear view system is intended to be used when the vehicle is in reverse. Please do not watch movies or operate the monitor while driving. It may result in accident because of distraction.
- Do not install the monitor where it may obstruct drivers view or obstruct an air bag device.
- Do not attempt to service this product on your own. If the system has any problem, please disconnect power to the unit and contact customer service.
- Dropping the unit may cause possible mechanical failure.

If you have any questions about this product, contact:

Customer Service

Rear View Safety Inc.
1680 Atlantic Ave # 301
Brooklyn NY 11213
Tel: 800-764-1028

www.rearviewsafety.com

BEFORE YOU BEGIN INTALLATION:

Before Drilling please check that no cable or wiring is on other side of wall. Please clamp all wires securely to reduce the possibility of them being damaged while vehicle is in use. Keep all cables away from hot or moving parts and electrical noisy components.

We recommend doing a Benchmark test before installations to insure that all components are working properly.

- Step 1** Choose the monitor and camera locations.

- Step 2** Install all cables in vehicle, when necessary a $\frac{3}{4}$ " (19mm) hole should be drilled for passing camera cable through vehicles walls. Install split grommets where applicable.

- Tep 3** Once all cable/ and wiring have been properly placed and routed, perform a system function test by temporarily connecting the system. If the system seems to not be operating properly see troubleshooting.

- Step 4** Backup camera used for monitoring while backing up must be connected to port # labeled "Backup" and blue trigger wire must be connected to reverse gear fuse circuit.

- Step 5** To automatically turn camera ON while shifting reverse, connect blue wire to reverse gear light/fuse and plug camera into port # labeled "Backup".

Installation Diagram

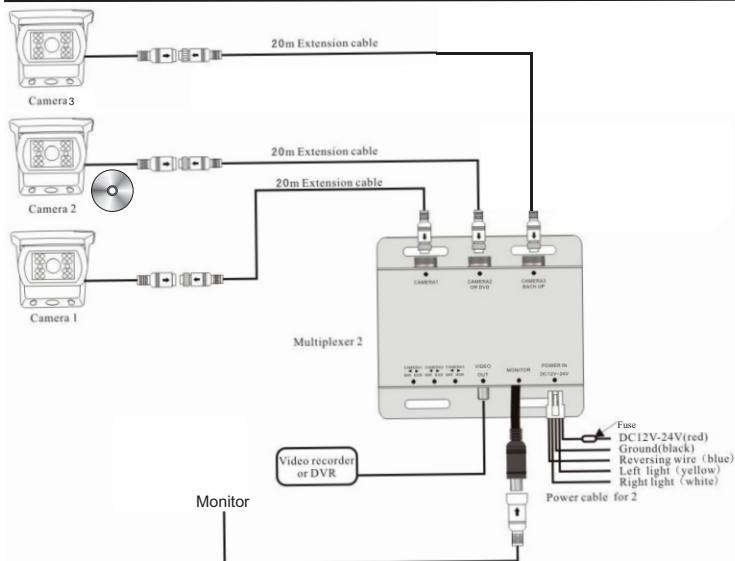

Notes

- When installing the 1 (one) camera setup use port # labeled "backup" on some models its port #2 and others port #3
- To automatically turn camera ON while shifting reverse, connect blue wire to reverse gear light/fuse and plug camera into port # labeled "Backup".

Installation

Notes

- To automatically have camera and monitor turn ON when vehicles activates, simply twist BLUE positive trigger 12V+ to Red Power line 12V+ and wire to ignition power which can be an accessory switch/fuse line.
- When using a 2 camera setup, use ports #'s 2 and 3
- For Safety reasons, on some 1 camera setup systems, when port # “Backup” is activated it overrides port #1. On these systems customer can have system “on” all the time (see note above) or just in “reverse” not both options.
- Audio only activates when REVERSE “BLUE” trigger is put to power
- Audio only works on two ports on multiplexer.
1. port labeled “BACKUP” 2. Port Labeled “DVD”.
- On some models when “BLUE” trigger is activated it overrides port#1 and port #1 cannot be seen until the “blue” trigger is deactivated.
- There is a built in voltage range for our systems which can handle 12-24 volts real consumption is 10 to 30 Volts.
- When installing a TWO camera setup, use ports #2 and #3 and use positive triggers Blue and White.
- **When installing all three cameras, use all three ports and connect all positive triggers to appropriate connections.**
- **When installing a one (1) camera setup, use port #3. Place blue trigger wire to reverse power line. Place red wire to positive and black wire to ground. Do not use yellow and white power cables.**

Features/Specifications

Features

- Free voltage (DC12V or DC24V) available for
- Video distributor and booster to maintain image quality.
- Auto switcher for video signal.
- Audio/Video output (RCA terminal).
- Camera 1/Camera 2/Camera 3 (Mirror/Normal image)
- Automatically switches to reverse image when backing vehicle.
- Night Vision: 18 powerful LEDs allow seeing rearward in total pitch darkness, as if using a spotlight.

Name	Description
Power	DC12V / DC24V
Dimension	115×101×33mm
Weight	0.26kg

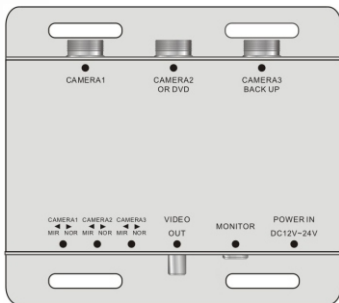
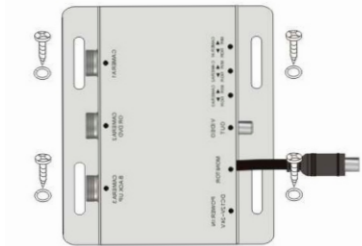

Specifications

FRONT VIEW

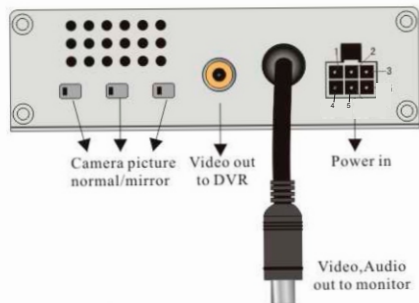

Pin Number	Description
1	BLUE: Reverse Gear Power input Port #3
2	Yellow: Camera - Port #2
3	RED:DC12-24V power input
4	BLACK: Ground
5	White: Right light Camera Port #1

GAMERA JACK

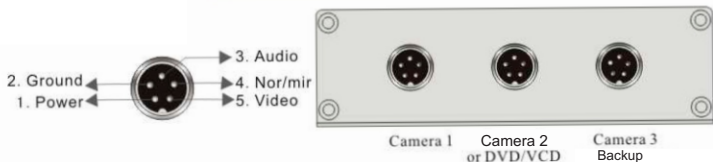

Positoning

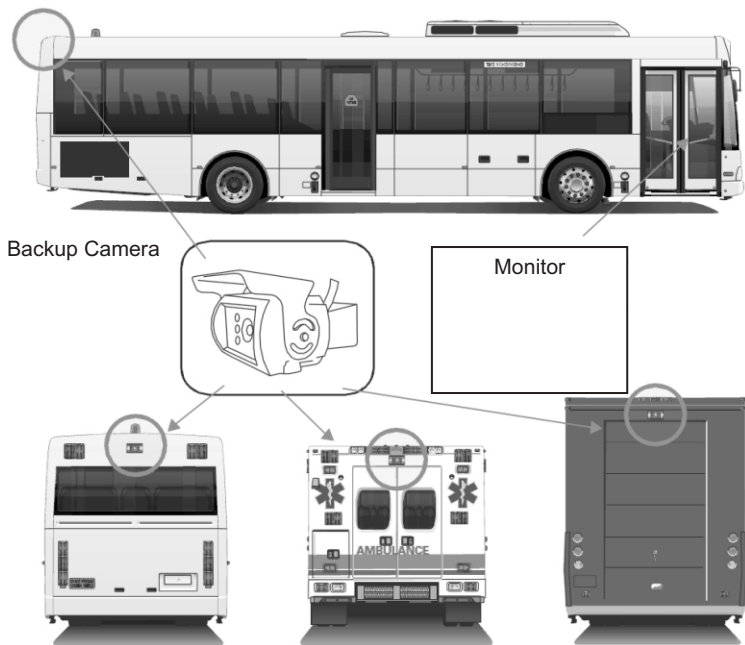

Dimensions - Camera (mm)

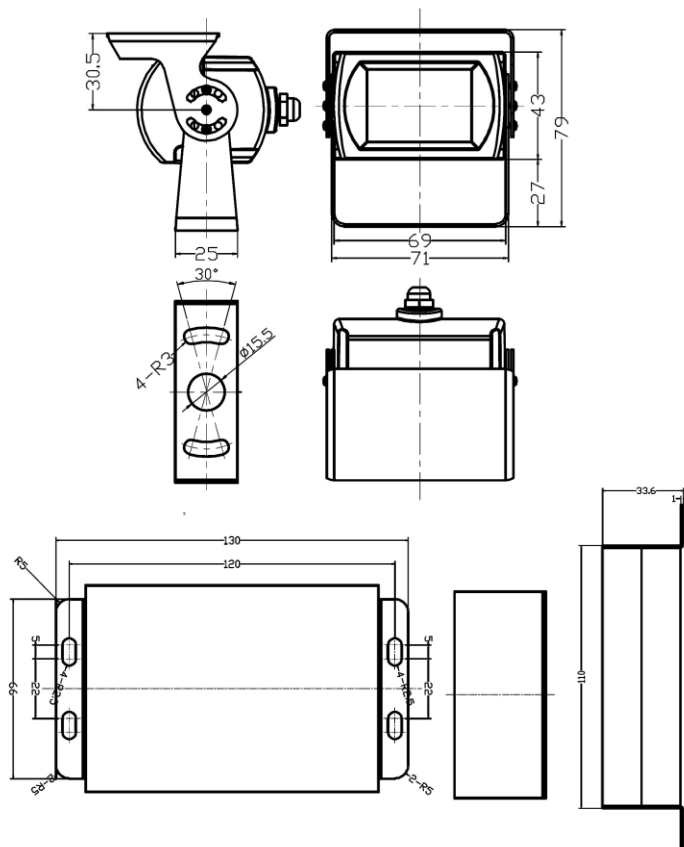

Dimensions - Monitor (mm)

(some models)

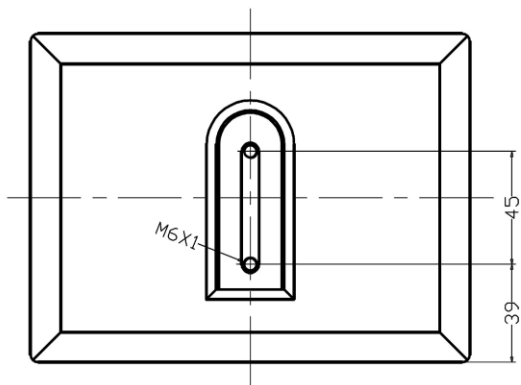
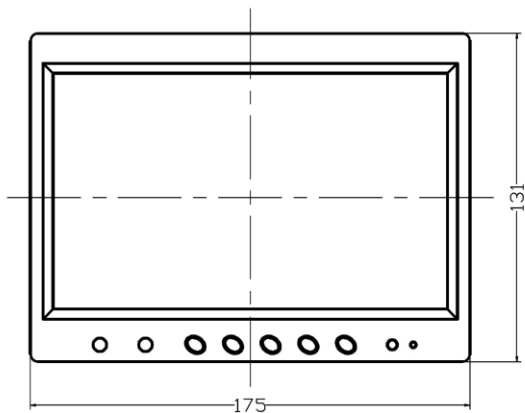

Product Info

Camera	1/4 Sharp Color CCD
Picture Elements	250,000 pixels
Gamma Correction	$\gamma=0.45$ to 1.0
Image Sensor	420TV lines NTSC:510(H)*492(V)
Lens	2.1mm
View Angle	130°
Sync System	Internal Synchronization
Infra-red distance	50 Feet (18 Infrared LED)
Usable Illumination	0 Lux (LED On)
Power Source	DC 12V (+/- 10%)
S/N Ratio	More than 48dB
Electronic Iris	1/50, 160-1/100,000sec
Video Output	1Vp.p 75ohm
IR Switch Control	CDS Automatic Control
Impact Rating	10G
Operating Temperature	-10°C - 50°C / RH 95% Max
Storage Temperature	-25°C - 60°C / RH 95% Max

Product Info

TFT LCD Monitor	
Screen Size	7"
Dot Resolution	1440(H)x234(V)
Display Format	16:9
Display Brightness	300
Viewing Angle	90° Min
Video Input	2 channel
Video Source	1Vp-p, 75Ω
Power Supply	DC 12V (DC 24) (+/-10%)
Power Consumption	5W
Operating Temperature	-10°C ~ +65° C
Video System	Auto NTSC/PAL
Overall Dimensions	7"(L) x 5" (H) x 1"(D)
Weight	400G
Impact Rating	5G
Active Area	154.08(H) x 86.58 (V)
Sync System	Internal

Rear View Safety Inc. reserve the right to change or modify product specifications or measurements without notice.

Monitor Control and Operation

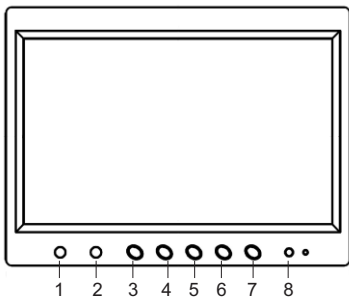

- 1 Earphone jack.
- 2 Audio/Video devices input jack.
- 3 Lower volume. When in Menu mode: selection key.
- 4 V1/V2 - Channel selection. Switches from Camera 1, 2 and 3.
- 5 Menu key:
 - Brightness
 - Contrast
 - Color
 - Volume
 - Display mode: 16:0 or 4:3
 - Tcon: rotate image 360°
 - AV select (same as V1/V2 - channel selection).
 - Language selection:
English, Chinese, Japanese, German, French, Spanish, Portuguese and Russian.
- 6 Higher volume. When in Menu mode: selection key.
- 7 Power - On/Off
- 8 Power indicator LED.

Monitor will not power up / no backlight on power button

- Check fuse
- Check 12v+ to monitor.
- Check ground connection.

No image on screen

- Verify camera is on correct camera input.
- Verify cable is connected to monitor.
- Verify camera is connected to cable.
- Connect known good camera and cable to monitor.
- Verify Blue trigger is receiving power.
 - *If image appears connect cable to existing camera*
 - *If image remains replace original cable.*
 - *If image disappears replace original camera.*

No audio

- Verify selected camera has audio.
- Verify volume setting.
- Confirm that the Blue audio trigger is connected to 12v+

Warranty

One Year Warranty

Rear View Safety Inc. warrants this product against material defects for a period of one year from date of purchase. We reserve the right to repair or replace any such defective unit at our sole discretion. Rear View Safety Inc. is not responsible for a defect in the system as a result of misuse, improper installation, damage or mis-handling of the electronic components. Rear View Safety Inc. is not responsible for consequential damages of any kind.

This warranty is void if: defects in materials or workmanship or damages result from repairs or alterations which have been made or attempted by others or the unauthorized use of nonconforming parts; the damage is due to normal wear and tear, this damage is due to abuse, improper maintenance, neglect or accident; or the damage is due to use of the Rear View Safety Inc. system after partial failure or use with improper accessories.

Warranty Performance

DURING THE ABOVE WARRANTY PERIOD, SHOULD YOUR REAR VIEW SAFETY PRODUCT EXHIBIT A DEFECT IN MATERIAL OR WORKMANSHIP, SUCH DEFECT WILL BE REPAIRED WHEN THE COMPLETE REAR VIEW SAFETY INC. PRODUCT IS RETURNED, POSTAGE PREPAID AND INSURED, TO REAR VIEW SAFETY INC. OTHER THAN THE POSTAGE AND INSURANCE REQUIREMENT, NO CHARGE WILL BE MADE FOR REPAIRS COVERED BY THIS WARRANTY.

Warranty Disclaimers

NO WARRANTY, ORAL OR WRITTEN, EXPRESSED OR IMPLIED, OTHER THE ABOVE WARRANTY IS MADE WITH REGARD TO THIS REAR VIEW SAFETY INC. REAR VIEW SAFETY INC. DISCLAIMS ANY IMPLIED WARRANTY OR MERCHANTABILITY OR FITNESS FOR A PARTICULAR USE OR PURPOSE AND ALL OTHER WARRANTIES. IN NO EVENT SHALL REAR VIEW SAFETY INC. BE LIABLE FOR ANY INCIDENTAL, SPECIAL, CONSEQUENTIAL, OR PUNITIVE DAMAGES OR FOR ANY COSTS, ATTORNEY FEES, EXPENSES, LOSSES OR DELAYS ALLEGED TO BE AS A CONSEQUENCE OF ANY DAMAGE TO, FAILURE OF, OR DEFECT IN ANY PRODUCT INCLUDING, BUT NOT LIMITED TO, ANY CLAIMS FOR LOSS OF PROFITS.



Rear View Safety, Inc.

1680 Atlantic Ave # 301

Brooklyn, N.Y. 11213

(800) 764-1028

www.rearviewsafety.com